

# **BLACK VOICES**

## **Technical Specifications**

**Black Voices has:**

**5 x Shennhiser Evolution 565 Radio Mics**

**5 x Shennhiser 'in ear' monitor packs with a transmitter**

**The system terminates in balanced XLR or "Jack"**

**We are happy for venues to provide an equivalent to the above – the 'in-ear' monitors are not compulsory if there is sufficient/adequate fold back on stage.**

**Obviously, there will be added freight charges (very expensive) if Black Voices has to bring its own system! It is important that they are good quality Radio Mics.**

**Venue to provide:**

**A sound system of adequate power for the venue based on 1 Kw of sound per 100 people. The system should be 3 way active over 3K and of GOOD quality i.e EV, Turbo, Nexo. No Peavey please.**

**Side fills are required in venues over 300.**

**At least 3/4 stage monitors.**

**Yamaha/Midas FOH desk 16 channel 2 sends minimum.**

**31 Band Graphic EQ on all outs i.e 4 channels pref. KT/BSS.**

**24 x PP3 Batteries**

**5 black Mic Stands (boom)**

**5 x back up Mics (SM87 or equivalent)**

**(2 x AKG 414 on boom stands if BV to use drums – to be agreed/confirmed in advance)**

**Please discuss technical matters, in the first instance, with**

**Aaron Mapp: 07957 368 774 or 0121 772 8204**

**Alternatively you can call:**

**Black Voices: 0121 441 1421 or 0207 740 1073**

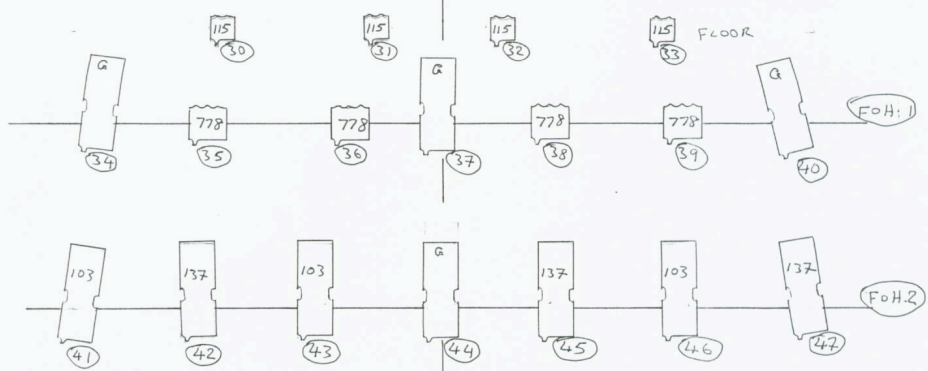
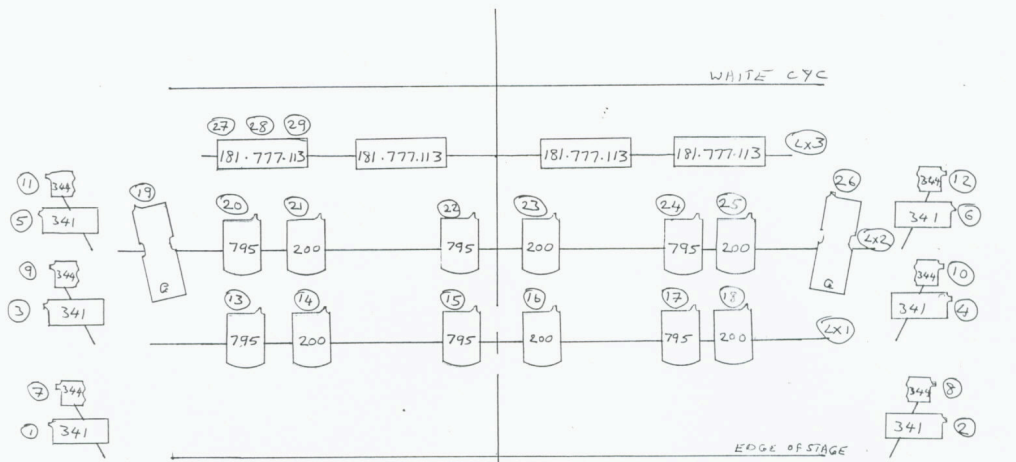

BLACK VOICES  
 NOT TO SCALE  
 SEPTEMBER 2003

	650W FRESNEL
	1K FRESNEL
	1K P.C.
	650W PROFILE
	1K PROFILE
	3 CELLS FLOORS